

LED PANEL ELMARK

WATERPROOF



GENERAL INFORMATION »

- ∴ Rated voltage: 220-240VAC
- ∴ Power: 7W; 10W; 16W; 23W
- ∴ Power supply: driver included
- ∴ Light source: SMD2835
- ∴ Colour temperature: 4000K; 6500K
- ∴ Housing: Milky white mask, soft light, not dazzling
- ∴ Body: polycarbonate (pc)
- ∴ Reflector: polycarbonate (pc)
- ∴ Ultra-thin lamp body
- ∴ Colour rendering index: Ra≥80
- ∴ Beam angle: 120°
- ∴ Average life: 30 000 hours
- ∴ Switch on/off: >20 000
- ∴ Starting time: <0.5s
- ∴ Power factor: >0.9
- ∴ Waterproof, dustproof and oily smoke
- ∴ Protection against dust and moisture: IP65
- ∴ Available in variant with an emergency kit
- ∴ LED panels is not dimmable

FEATURES »

- ∴ Completely replace traditional fluorescent lighting
- ∴ Safety, low voltage operation
- ∴ Suitable for mounting in suspended ceiling Armstrong type
- ∴ Emit a very pleasant and even light with very low glare factor due to the diffusion lens
- ∴ Low power consumption
- ∴ Instant light with maximum luminous flux
- ∴ Environmentally friendly - do not emit mercury and lead
- ∴ No ultraviolet and infrared rays
- ∴ Resistant to shock and vibration
- ∴ Suitable for home, offices, halls, shops, hospitals

TECHNICAL SPECIFICATION SHEET

[PRODUCT DETAILS »](#)

Catalogue number	Catalogue number with Emergency kit	Watt (W)	Whole fixture lumens (lm)	Colour temp. (K)	Colour body
99LED607IP65	99LED607IP65E	7	660	4000	white
99LED607IP65CW	99LED607IP65CWE	7	660	6500	white
99LED610IP65	99LED610IP65E	10	770	4000	white
99LED610IP65CW	99LED610IP65CWE	10	770	6500	white
99LED616IP65	99LED616IP65E	16	1300	4000	white
99LED616IP65CW	99LED616IP65CWE	16	1300	6500	white
99LED623IP65	99LED623IP65E	23	1750	4000	white
99LED623IP65CW	99LED623IP65CWE	23	1750	6500	white

[DIMENSIONS »](#)

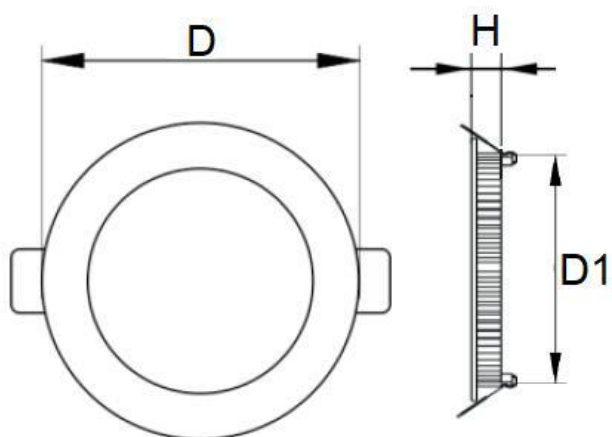

Catalogue number	Diameter (mm)	Diameter1 (mm)	Height (mm)
99LED607IP65	115	100-110	27
99LED607IP65CW	115	100-110	27
99LED610IP65	170	150-160	27
99LED610IP65CW	170	150-160	27
99LED616IP65	220	200-210	27
99LED616IP65CW	220	200-210	27
99LED623IP65	240	220-230	39
99LED623IP65CW	240	220-230	39



TECHNICAL SPECIFICATION SHEET

LED EMERGENCY KIT SPECIFICATIONS »



- ∴ General information »
- ∴ Voltage: AC85-265V 50Hz
- ∴ Emergency Output: 3-40W
- ∴ Emergency Time: 2hrs (120mins)
- ∴ Battery: 3.7V 2400mAh
- ∴ Emergency Switching Time: <2s
- ∴ AC Fuse: 250V 1A
- ∴ DC Fuse: 250V 5A
- ∴ Luminous Flux: >100lm
- ∴ Light Source: LED
- ∴ Working temperature: -10°C +55°C
- ∴ IP Rate: IP30
- ∴ Emergency kit with a possibility for work in an emergency regime more than two hours.

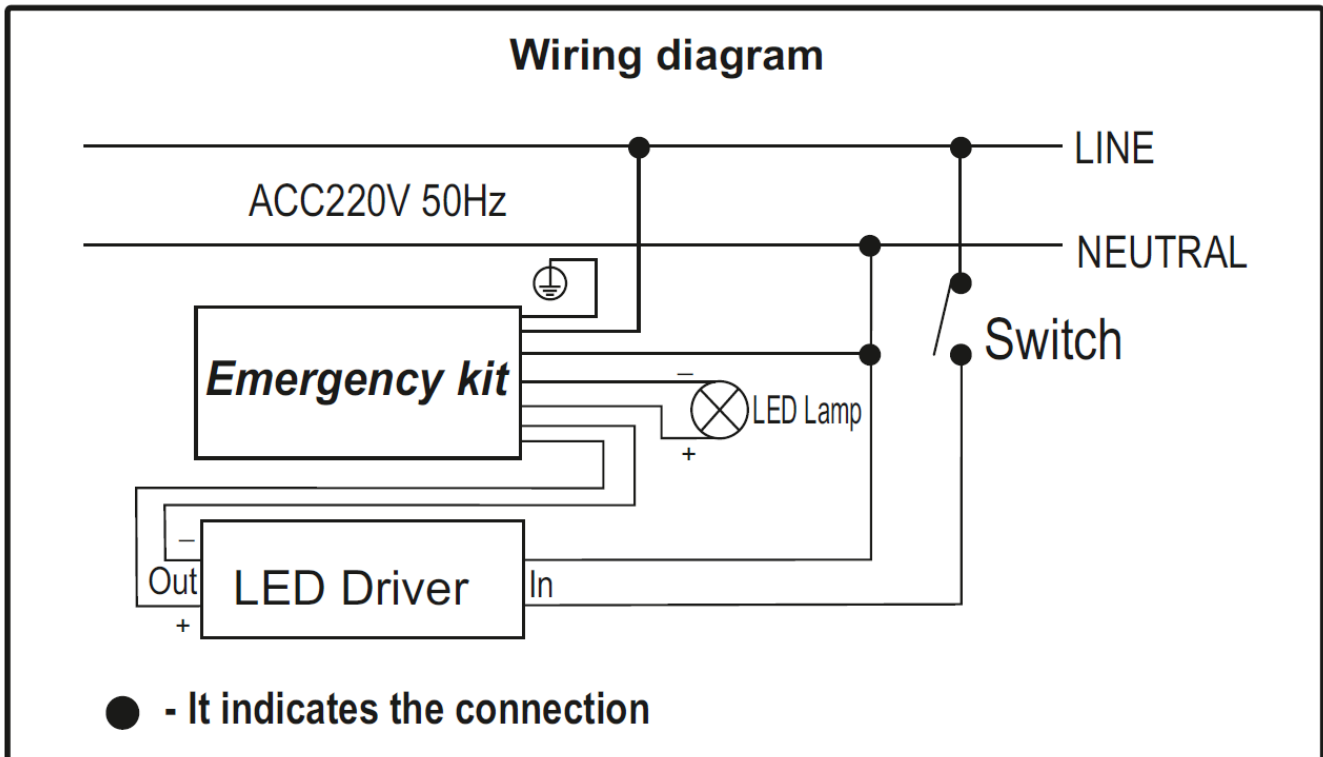
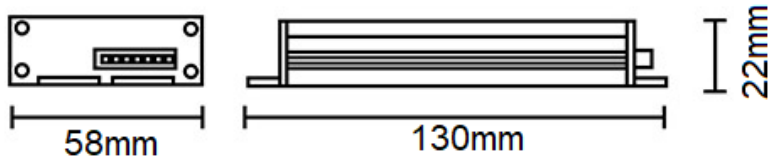

● Red = Charging ● Blue = Emergency ● Green = Power

TECHNICAL SPECIFICATION SHEET

[ADDITIONAL INFORMATION »](#)



ELMARK
lighting

99LED607IP65



This luminaire contains built-in LED lamps.

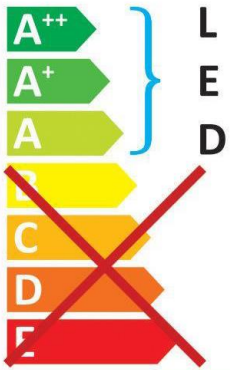

L
E
D

The lamps cannot be changed in the luminaire.

874/2012



Catalogue number	Barcode	Packing/Box (pcs)
99LED607IP65	3800131235619	1/20
99LED607IP65CW	3800131235626	1/20
99LED610IP65	3800131235633	1/20
99LED610IP65CW	3800131235640	1/20
99LED616IP65	3800131235657	1/20
99LED616IP65CW	3800131235664	1/20

